

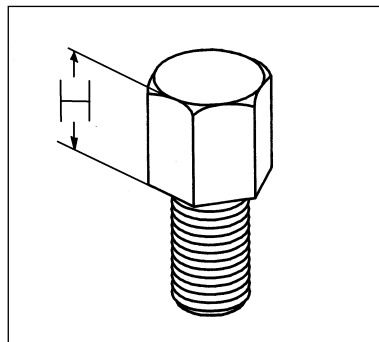

**THAME**  
ENGINEERING

# WORKPIECE HEIGHT PINS & BOLTS

## WORKPIECE HEIGHT PINS



- Material: En32 Hardened & Ground
- Ordering: Please state Thame Part No.
- Workpiece height pins are for use with Adjustagrip hard jaws or with special jaws requiring a workpiece height location.

THAME PART NO	H	WIDTH ACROSS FLATS	"P" THREAD	SUITS ADJUSTAGRIP JAW RANGES
IT05	5	10	M6	LA, LB, MA, MB
IT10	10			
IT15	15			
IT20	20			
IU05	5	13	M8	LC, LD, LE, LF, MC,,MD, ME, MF
IU10	10			
IU15	15			
IU20	20			
IU25	25			



## QUICK JAW CHANGE BASE JAW BOLTS

THAME PART NO	BOLT SIZE	TO SUIT BASE JAW TYPE	THAME PART NO	BOLT SIZE	TO SUIT BASE JAW TYPE
QA12	M8 × 1 × 20	MFG 160, MFG 200	QB12	M8 × 20	GBK 140, GBK 160, GBK 200
QA32	M12 × 1.5 × 30	MFG 250	QB31	M12 × 25	GBK 250, GBK 315
QA33	M12 × 1.5 × 35	MFG 315	QB32	M12 × 30	GBK 400
QA54	M16 × 1.5 × 40	MFG 400	QB55	M16 × 45	GBK 500, GBK 630