

CHUCK JAW IDENTIFICATION DATASHEET

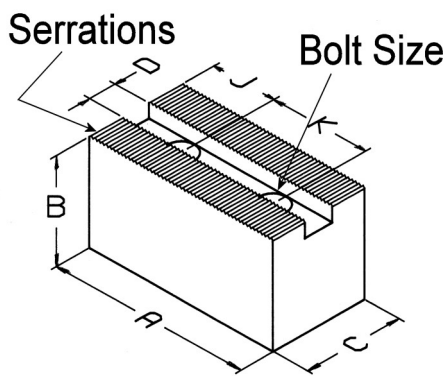

Please use this sheet to help us identify the correct jaws to fit your chuck. Chuck manufacturers often supersede or change specification on jaw location details so it is important to check that dimensions entered below correspond with your existing top jaws, master jaws and chuck. It is also important to measure accurately we recommend you use a vernier when measuring.

SERRATED TOP JAWS



Serrations– pitch and angle: 1.5mm x 60° / 1/16”x 90° 3mm x 60° / 3/32”x 90°	
D = Slot width	
K = Hole Centre Spacing	
Bolt size *	

* the bolt holes will have clearance on the bolt size

SLOT AND TENON TOP JAWS

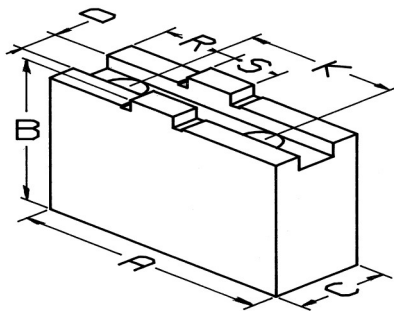

D = Slot width	
S = Tenon width	
K = Hole centre spacing	
Bolt size	

SCROLL JAWS

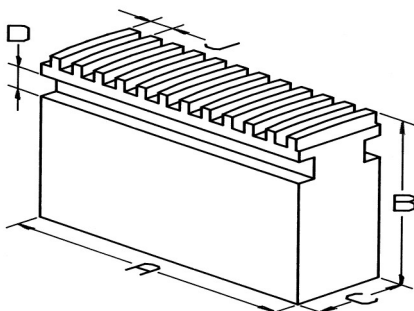

C = Jaw width	
D = Slot width	
J = Tooth pitch	