

DDL

OUTSDIE DRAW-DOWN CHUCK

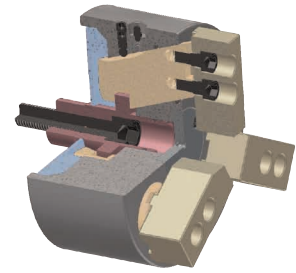

The workpiece is pulled flush with the locators before clamping from the outer diameter guaranteeing superior accuracy.

The DDL chuck offers outstanding accuracy for the machining of perpendicular and parallel angles.

Interchangeable top jaws facilitate work on multiple workpieces.

The dust-proof design increases durability by preventing debris from entering the chuck.

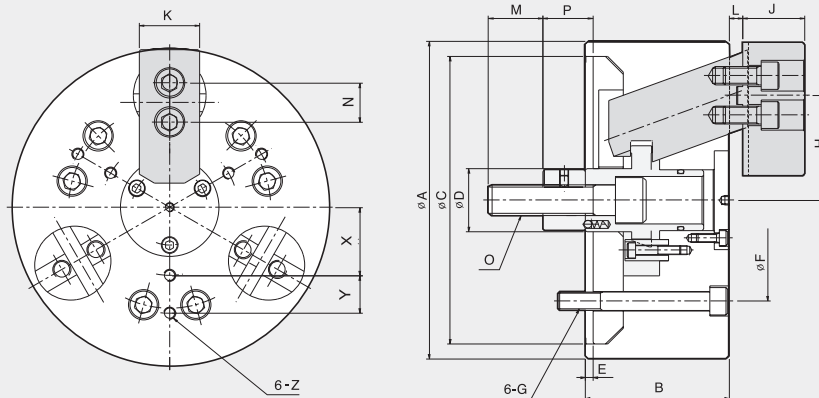

Dimensions

	A	B	C(h ⁷)	D	E	F	G	Hmax.	Hmin.	J	K	Lmax.	Lmin.	M	N	O	Pmax.	Pmin.	X	Y	Z
DDL-05	130	70	80	30	5	100	3-M8	44	41.5	25	30	10.5	3.5	25	-	M12	19	12	30	-	3-M6
DDL-06	165	85	140	35	5	104.8	M10	58	54.4	31	35	14	4	36	-	M16	33	23	35	20	M6
DDL-08	210	95	190	42	5	133.4	M12	71	67.4	41	40	14	4	36	26	M20	38	28	45	25	M8
DDL-10	254	110	230	52	5	171.4	M16	85	79.6	46	50	19	4	46	32	M24	47	32	55	30	M8
DDL-12	304	125	230	55	5	171.4	M16	102	96.6	51	60	19	4	50	36	M27	47	32	70	35	M10
DDL-15	381	140	300	90	8	230	M20	133.5	126.5	60	70	26	6	50	40	M30	71	51	95	45	M12

Specifications

	Clamping Force (kgf)	Max. Drawbar Pull (kgf)	Jaw Stroke mm(dia)	Plunger Stroke (mm)	Chucking Diameter (mm)		Max. Speed (r.m.p)	Weight (kg)	GD ² (kgf·m ²)
					Standard	Top Jaw Type			
DDL-05	2000	1000	5.0	7	15~65	15~60	3500	7.3	0.07
DDL-06	2500	1500	7.2	10	35~85	35~80	3500	14	0.18
DDL-08	4500	2500	7.2	10	40~200	40~150	3000	27	0.66
DDL-10	6000	3500	10.8	15	50~250	50~200	2500	46	1.50
DDL-12	7500	4500	10.8	15	50~300	50~250	2000	68	3.20
DDL-15	9000	5500	14.5	20	60~380	60~320	1500	110	9.00