

# HC

## STANDARD 3-JAW CLOSED-CENTER CHUCK (110MM - 304MM)

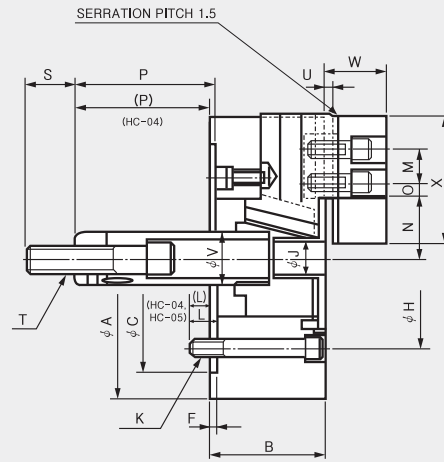

Standard 3-jaw wedge-type closed-center chuck

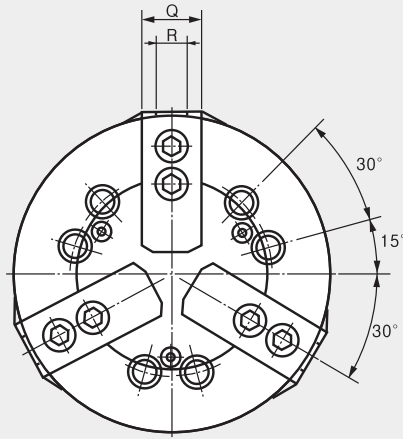

### Dimensions

	A	B	C(H6)	F	H	J	K	L	M	Nmax.	Nmin.	Omax.	Omin.	Pmax.	Pmin.	Q	R	S	T	U	V	W	X
HC-04	110	52	60	6	80	-	3-M8X55	12	14	23.3	20.1	11.25	8.25	17	3	23	10	25	M10×1.5	3	26	27	55
HC-05	135	55	80	7	100	-	3-M8X60	14	19	30.4	27.2	11.25	6.75	6	-8	23	10	35	M12×1.75	3	28	29	62
HC-06	165	74	140	5	104.8	21	6-M10X90	14	20	37.8	33.55	13.75	7.75	98(100)	79.5(81.5)	31	12	36	M16×2.0	4	34	35	72
HC-08	210	85	170	5	133.4	25	6-M12X100	20	25	46.3	41.9	22.25	11.75	109(125)	90(106)	35	14	36	M20×2.5	5	38	42	95
HC-10	254	89	220	5	171.4	34	6-M16X105	18	30	51.1	46.7	30.75	11.25	119(158)	94(133)	40	16	36	M20×2.5	5	45	46	110
HC-12	304	106	220	6	171.4	34	6-M16X120	18	30	61	55.75	48.75	12.75	142(163)	112(133)	49	18	36	M24×3.0 (M20×2.5)	5	50	53.5	129

※ HC-21 and HC-24 are available with M22 or M24 mounting bolts.  
 ※ HC-04 and HC-05 have 3 mounting bolts located 120° apart.  
 ※ HC-21 and HC-24 have 6 mounting bolts located 60° apart.

※ The numbers in parentheses in columns P and T are also available upon request.  
 ※ HC-32 and HC-40 are groove-type chucks with 19.025mm keys.

### Specifications

	Jaw STROKE Diameter (mm)	PLUNGER STROKE (mm)	Grip Dia. (mm)		Permissible Input Force KN(kgf)	Max. Static Gripping Force KN(kgf)	Max. rp.m min <sup>-1</sup> (rp.m)	weight kgf	GD <sup>2</sup> N·m <sup>2</sup> (kgf·cm <sup>2</sup> )	Operating Cylinder		Max. Hydraulic Pressure MPa(kgf/cm <sup>2</sup> )	Operating HARD JAW	KITAKAWA Model
			Max.	Min.						Hydraulic	Pneumatic			
HC-04	6.4	14	110	8	8.2(836)	22.8(2325)	6000	4.1	0.29(0.03)	Y-0715R(RE)	AY-1315R	2.4(24.5)	HB04N1	N-04
HC-05	6.4	14	135	16	8.2(836)	25.2(2570)	5500	6.2	0.59(0.06)	Y-0715R(RE)	AY-1315R	2.4(24.5)	HB04N1	N-05
HC-06	8.5	18.5	165	19	18(1835)	52.5(5353)	5270	13	1.77(0.18)	Y-1020R(RE)	AY-1720R	2.6(26.5)	HB06A1	N-06
HC-08	8.8	19	210	23	25(2549)	75(7648)	4760	25	5.39(0.55)	Y-1225R(RE)	AY-2225R	2.5(25.5)	HB08A1	N-08
HC-10	8.8	25	254	24	29(2957)	108(11013)	4010	37	11.77(1.20)	Y-1225R(RE)	AY-2225R	2.8(28.6)	HB10A1	N-10
HC-12	10.5	30	304	26	41(4181)	156(15907)	3380	57.3	28.44(2.90)	Y-1530R(RE)	AY-2730R	2.7(27.5)	HB12B1	N-12

※ Specifications are subject to change without notice. ※ Maximum turning speed is based upon actual measurements.

# HC

## STANDARD 3-JAW CLOSED-CENTER CHUCK (381MM - 1000MM)



Standard 3-jaw wedge-type closed-center chuck

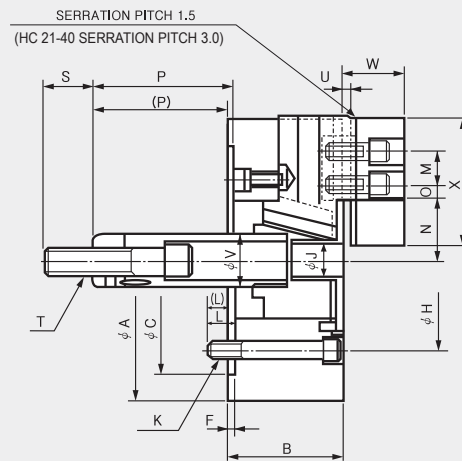
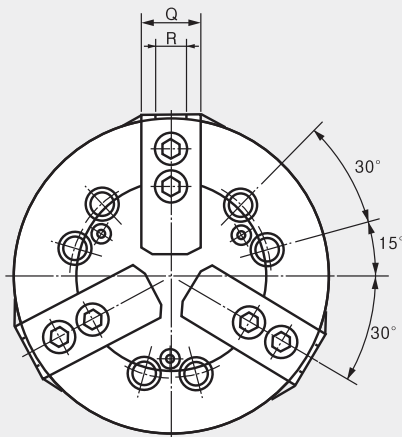

### Dimensions

	A	B	C(H6)	F	H	J	K	L	M	Nmax.	Nmin.	Omax.	Omin.	Pmax.	Pmin.	Q	R	S	T	U	V	W	X
HC-15	381	114	300	6	235.0	-	6-M20X130	30	43	77.5	69.5	48.75	23.25	104	69	50	25.5	55	M30x3.5	2	60	61	135
HC-18	450	114	300	6	235.0	-	6-M20X130	30	43	108	100	48.75	23.25	92	57	50	25.5	55	M30x3.5	2	60	61	135
HC-21	530	125	380	6	330.2	-	6-M22X140	31	60	86	78	93.5	27.5	97	62	65	25	55	M30x3.5	3	60	70	180
HC-24	610	125	380	6	330.2	-	6-M22X140	31	60	125	117	93.5	27.5	97	62	65	25	55	M30x3.5	3	60	70	180
HC-32	800	150	380	6	330.2	65	6-M24	39	76.2	117.3	102.3	196.9	-22.4	3	-35	75	12.7	70	M30x3.5	8	70	83	165
HC-40	1000	180	520	8	463.6	50	6-M24	32	76.2	212.8	187.8	169.8	17.4	30	-27	110	30	65	M36x4.0	4	70	106	270

※ HC-21 and HC-24 are available with M22 or M24 mounting bolts.

※ HC-04 and HC-05 have 3 mounting bolts located 120° apart.

※ HC-21 and HC-24 have 6 mounting bolts located 60° apart.

※ The numbers in parentheses in columns P and T are also available upon request.

※ HC-32 and HC-40 are groove-type chucks with 19.025mm keys.

### Specifications

	Jaw STROKE Diameter. (mm)	PLUNGER STROKE (mm)	Grip Dia. (mm)		Permissible Input Force KN(kgf)	Max. Static Gripping Force KN(kgf)	Max. rp.m min <sup>-1</sup> (rp.m)	weight kgf	GD <sup>2</sup> N·m <sup>2</sup> (kgf·m <sup>2</sup> )	Operating Cylinder		Max. Hydraulic Pressure MPa(kgf/cm <sup>2</sup> )	Operating HARD JAW	KITAKAWA Model
			Max.	Min.						Hydraulic	Pneumatic			
HC-15	16	35	381	71	82 (8362)	249 (25391)	3040	96	70.61(7.2)	Y-2035R(RE)	-	3.2 (32.6)	HB15N1	N-15
HC-18	16	35	450	133	82 (8362)	249 (25391)	2710	124	92.2 (9.4)	Y-2035R(RE)	-	3.2 (32.6)	HB15N1	N-18
HC-21	16	35	530	62	82 (8362)	273 (27838)	1940	180	188.3 (19.2)	Y-2035R(RE)	-	3.2 (32.6)	HB18B2	N-21
HC-24	16	35	610	152	82 (8362)	273 (27838)	1760	223	271.6 (27.7)	Y-2035R(RE)	-	3.2 (32.6)	HB18B2	N-24
HC-32	15	38	800	200	120 (12170)	215 (21805)	800	350	609.1 (61)	Y-2050R(RE)	-	40.8	HB32SB2	-
HC-40	15	23	1000	330	180 (18256)	320 (32454)	630	600	1721.8 (174.5)	Y-2060RE	-	40.8	HB40SB2	-

※ Specifications are subject to change without notice.

※ Maximum turning speed is based upon actual measurements.

# HC

## 3-JAW HYDRAULIC / 4-JAW INDEPENDENT CHUCK (800MM - 1600MM)



3-Jaw hydraulic / 4-jaw independent closed-center chuck with tongue & groove master jaws

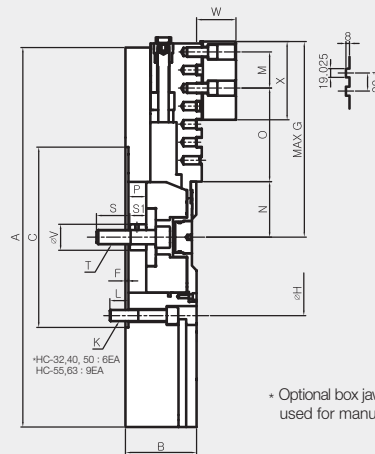
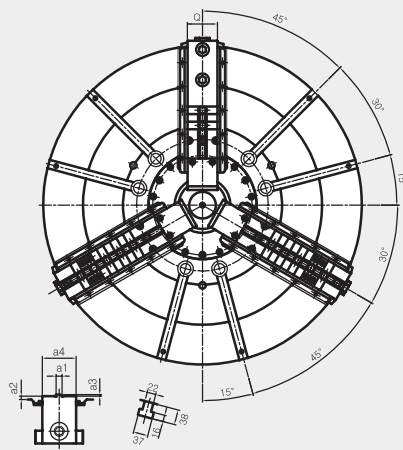

\* Optional box jaws can be used for manual operation.

### Dimensions

	A	B	C(H6)	F	G	H	K	L	M	Nmax.	Nmin.	Omax.	Omin.	Pmax.	Pmin.	Q	S	S1	T	V	W	X	a1	a2	a3	a4
HC-32	800	150	380	6	442.5	330.2	M24X120L	39	76.2	117.6	102.7	196.9	44.5	38	0	75	70	35	M30x125L	55	83	165	12.7	8	3	75
HC-40	1000	180	520	8	509.6	463.6	M24X140L	32	76.2	217.3	194.3	91.1	14.9	60	3	110	65	35	M36x130L	70	106	270	30	-4	4	85
HC-50	1250	180	520	8	623.9	463.6	M24X140L	32	76.2	217.3	194.3	205.4	14.9	60	3	110	65	35	M36x130L	70	106	270	30	-4	4	85
HC-55	1400	220	720	8	710.6	647.6	M24X160L	36	76.2	250	226	259.4	30.8	82	22	110	65	35	M36x130L	70	104	270	30	-6	4	110
HC-63	1600	220	720	8	786.8	647.6	M24X160L	36	76.2	250	226	335.6	30.8	13	22	110	65	35	M36x130L	70	104	270	30	-6	4	110

### Specifications

	Jaw STROKE Diameter (mm)	Manual Setting (Radial)	PLUNGER STROKE (mm)	Grip Dia. (mm)		Permissible Input Force KN(kgf)	Max. Static Gripping Force KN(kgf)	Max. r.p.m min <sup>-1</sup> (r.p.m)	weight kgf	GD <sup>2</sup> N·m <sup>2</sup> (kgf·m <sup>2</sup> )	Cylinder	Max. Hydraulic Pressure MPa(kgf/cm <sup>2</sup> )	Operating HARD JAW
				Max.	Min.								
HC-32	15	30	38	800	200	120 (12170)	215 (21805)	800	350	601.9 (61)	Y-2560	40.8	HB32GB
HC-40	23	30	23	1000	330	180 (18256)	320 (32454)	630	600	1721.8 (174.5)	Y-2560	40.8	HB40GB
HC-50	23	30	57	1250	330	180 (18256)	320 (32454)	500	800	2169 (220)	Y-2560	40.8	HB40GB
HC-55	24	40	60	1400	460	200 (20394)	360 (36710)	450	1350	2760 (280)	Y-2560	46	HB40GB
HC-63	24	40	60	1600	460	200 (20394)	360 (36710)	400	1850	4930 (500)	Y-2560	46	HB40GB

\* Specifications are subject to change without notice. \* Maximum turning speed is based upon actual measurements.