

HCL

CLOSED-CENTER LONG-STROKE CHUCK

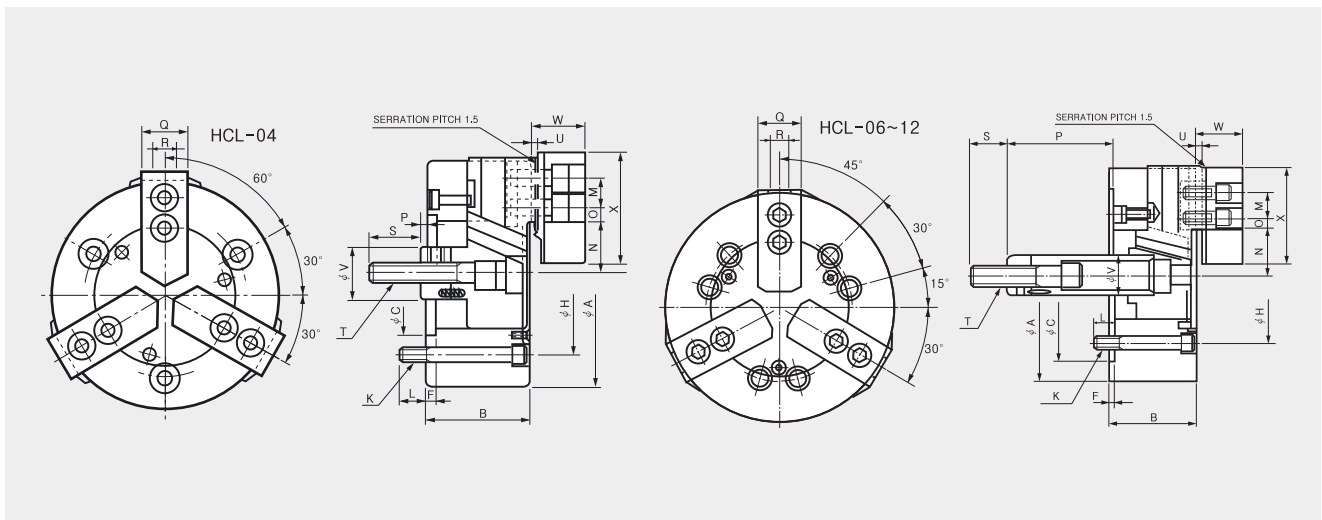

3-jaw wedge-style power chuck



Dimensions

	A	B	C(H6)	F	H	K	L	M	Nmax.	Nmin.	Omax.	Omin.	Pmax.	Pmin.	Q	R	S	T	U	V	W	X
HCL-04	110	52	60	6	80	3-M8	12	14	26.5	20.45	9.75	6.75	24	9	23	10	25	M10×1.5	3	26	27	55
HCL-06	165	74	140	5	104.8	6-M10	14	20	40.5	34	13.75	9.25	99.5	79.5	31	12	36	M16×2.0	4	34	35	72
HCL-08	210	85	170	5	133.4	6-M12	20	25	48.1	40	20.75	11.75	111	90	35	14	36	M20×2.5	5	38	42	95
HCL-10	254	89	220	5	171.4	6-M16	18	30	54.4	43.35	29.5	11.5	119	94	40	16	36	M20×2.5	5	45	46	110
HCL-12	304	106	220	6	171.4	6-M16	18	30	65.7	56	42.75	12.75	138	108	50	18	46	M24×3.0	5	50	54	129

Specifications

	Jaw STROKE Diameter (mm)	PLUNGER STROKE (mm)	Grip Dia. (mm)		Permissible Input Force KN(kgf)	Max. Static Gripping Force KN(kgf)	Max. r.p.m KN(kgf)	weight kgf	GD ² N·m ² (kgf·m ²)	Operating Cylinder	Max. Hydraulic Pressure MPa(kgf/cm ²)	Operating HARD JAW	KITAKAWA Model
			Max.	Min.									
HCL-04	12.1	15	110	12	10 (1020)	14.4 (1468)	5000	4.1	0.29 (0.03)	Y-0715R(RE)	2.9 (29.6)	HB04N1	NL-04
HCL-06	13	20	165	22	21 (2141)	39 (3977)	4300	12	1.76 (0.18)	Y-1020R(RE)	3.0 (30.6)	HB06A1	NT-06
HCL-08	16.2	25	210	23	30 (3059)	60 (6118)	3600	22.9	5.39 (0.55)	Y-1225R(RE)	2.9 (29.6)	HB08A1	NT-08
HCL-10	18.1	28	254	27	40 (4079)	81 (8260)	3100	34.6	11.8 (1.20)	Y-1530R(RE)	2.8 (28.6)	HB10A1	NT-10
HCL-12	19.4	30	304	33	54 (5506)	111 (11319)	2500	60	28.4 (2.90)	Y-1530R(RE)	3.6 (36.7)	HB12B1	NT-12

* Specifications are subject to change without notice. * Maximum turning speed is based upon actual measurements.