

# HS

## STANDARD 3-JAW HIGH-SPEED OPEN-CENTER CHUCK

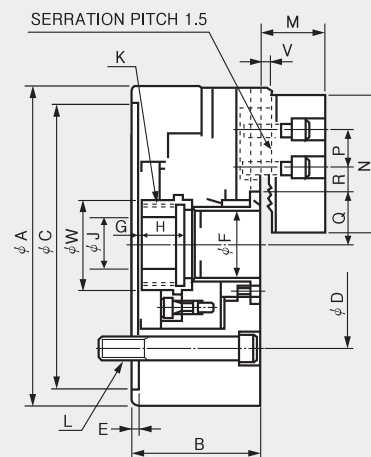

Standard high-speed 3-jaw wedge-type open-center power chuck

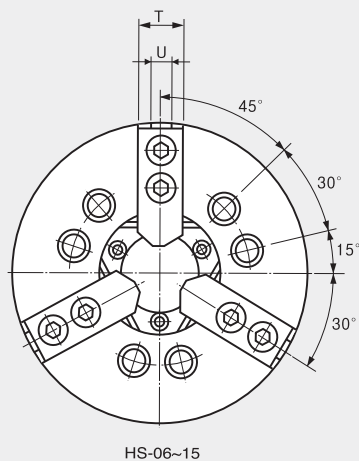

### Dimensions

	A	B	C(H6)	D	E	F	Gmax.	Gmin.	H	J	Kmax.	L	M	N	P	Qmax.	Qmin.	Rmax.	Rmin.	T	U	V	W
HS-05	135	60	110	82.6	4	33	1	-9	20	12	M40×1.5	3-M10×60	26	54	14	26.5	23.8	19.75	7.75	23	10	2	45
HS-06	169	81	140	104.8	5	46	11	-1	19	20	M55×2.0	6-M10×95	29	72	20	32	29.25	22.75	9.25	31	12	2	60
HS-08	210	91	170	133.4	5	52	14.5	-1.5	20.5	30	M60×2.0	6-M12×105	39	95	25	38.7	35	29.75	14.75	35	14	2	66
HS-10	254	100	220	171.4	5	77	8.5	-10.5	25	45	M85×2.0	6-M16×120	43	110	30	51	46.6	33.75	14.25	40	16	2	94
HS-12	304	110	220	171.4	6	91	8	-15	28	50	M100×2.0	6-M16×130	50.5	111	30	61.3	56	45.75	15.75	49	21	2	108

\* Blank and machined draw-nuts are available.

### Specifications

	Thru Hole Diameter. (mm)	Grip Dia. (mm)		Jaw STROKE Diameter. (mm)	PLUNGER STROKE (mm)	Permissible Input Force KN(kgf)	Max. Static Gripping Force KN(kgf)	Max. r.p.m min-(r.p.m)	weight kgf	GD <sup>2</sup> N m <sup>2</sup> (kgf·m <sup>2</sup> )	Operating Cylinder	Max. Hydraulic Pressure MPa(kgf/cm <sup>2</sup> )	Operating HARD JAW	KITAKAWA Model
		Max.	Min.											
HS-05	33	135	12	5.4	10	17.5 (1784)	36 (3671)	7000	6.7	0.69 (0.07)	SYH-1036 (SYH-1036)	3.43 (35.0)	HB04N1	B-205
HS-06	46	169	15	5.5	12	22 (2243)	57 (5812)	6000	11.9	2.26 (0.23)	SH-13046 (SYH-1246)	2.8 (28.6)	HB06A1	B-206
HS-08	52	210	13	7.4	16	34.8 (3549)	86 (8769)	5000	22.3	6.67 (0.68)	SH-15052 (SYH-1552)	2.65 (27)	HB08A1	B-208
HS-10	77	254	31	8.8	19	43 (4385)	111 (11319)	4200	34.5	2.36 (1.26)	SH-18077 (SYH-1877)	2.7 (27.5)	HB10A1	B-210
HS-12	91	304	34	10.6	23	55 (5608)	144 (14686)	3300	55.3	28.93 (2.95)	SH-21091 (SYH-2091)	2.7 (27.5)	HB12N1	B-212

\* HS-05 have 3 mounting bolts located 120° apart.

\* Maximum turning speed is based on actual measurements.

\* Specifications are subject to change without notice.