

# IAN AUTO-INDEXING CHUCK

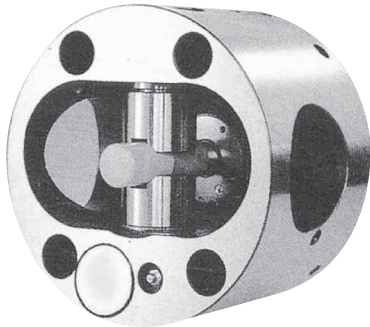
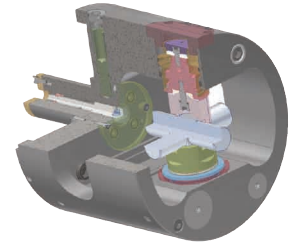

The fully automated IAN chuck is very efficient for machining components with orthogonal axes of 90°, 180°, 270°, or 360° such as valve bodies, spiders, and fittings.

Indexing movements during actuation enables quick change between multiple working axes.

The effects of centrifugal force during actuation are reduced delivering higher precision results.

The proximity switch ensures proper indexing at 90°, 180°, 270°, and 360° intervals.

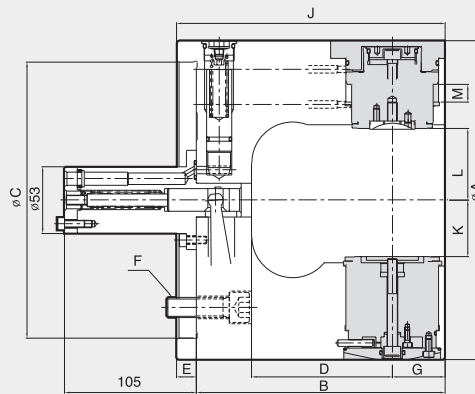
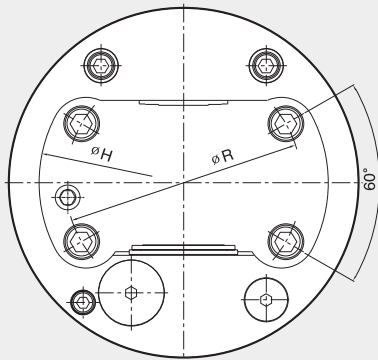

## Dimensions

	A	B	C(h <sup>1</sup> )	D	E	F	G	H	J	K	L	M	R
IAN-230	230	172	170	102	16	M12	30	206	188	42.5	54.5	15	133.4
IAN-254	254	198	220	112	16	M16	42	228	214	45	57	17	171.4
IAN-280	280	211	220	125	16	M16	42	250	227	58	70	17	171.4

## Specifications

	Clamp Piston Area (cm <sup>2</sup> )	Max. Pressure (kgf/cm <sup>2</sup> )	Max. Speed (r.m.p)	Weight (kg)	GD <sup>2</sup> (kgf·m <sup>2</sup> )
IAN-230	30	45	3000	32	0.27
IAN-254	43	45	2500	45	0.47
IAN-280	43	45	2300	55	0.88

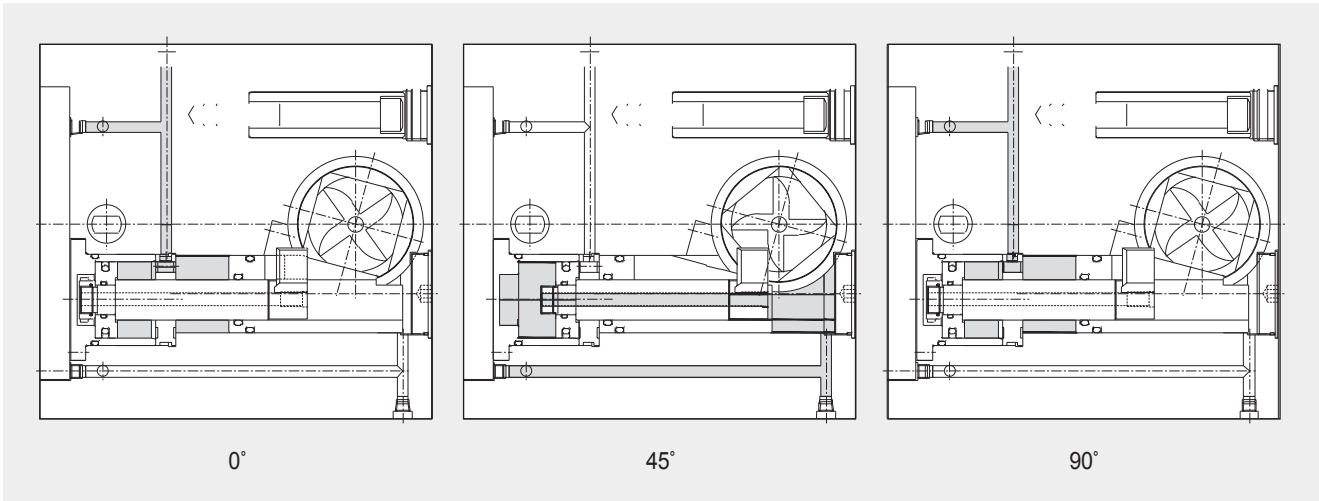

Work Piece

