

PBL

UNIVERSAL BALL-LOCK POWER CHUCK

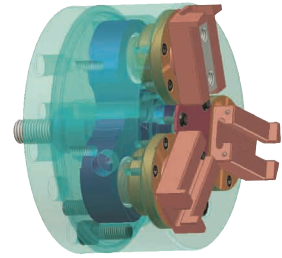

Cast and forged metals can be clamped from the inner and outer diameters. The PBL chuck can grip flat-edged workpieces or workpieces with a taper less than 10°.

Equalization allows the jaws to move in up to 5 degrees for better clamping on irregularly-shaped workpieces.

The PBL chuck is ideal for the machining of shafts.

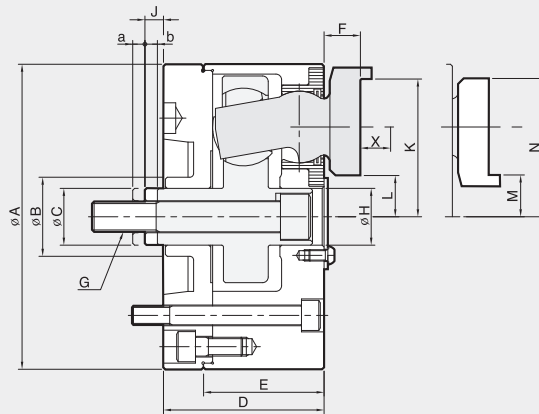
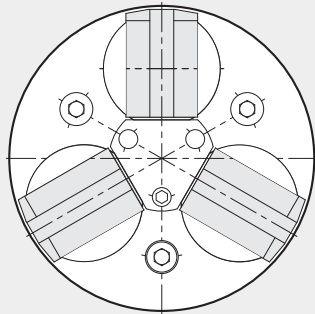

Dimensions

	A	B MIN	C	D	E	F	G	H	J	a	b	K	L	M	N	X
PBL-06	162	41.1	30.16	85.2	59.2	19.3	M16	Φ30.170	10.6	4.4	5.1	73.15	22.2	17.3	78	24.9
PBL-08	200	45	31.75	100	70	23.3	M16	Φ31.760	12	4.0	5.3	88.95	25.35	22.1	92.2	29.4
PBL-10	254	58	41.27	118	86.6	29.1	M18	Φ41.285	13.5	4.0	8.0	112.7	30.3	30	112.7	36.5
PBL-12	300	58	41.27	118	86.6	29.1	M18	Φ41.285	13.5	4.0	8.0	133.27	50.8	50.6	133	36.5
PBL-15	381	83	57.16	131	96.1	32.4	M24	Φ57.160	24.7	12.7	10.3	171.45	69.8	65.8	176	41.9
PBL-18	457	120.7	88.90	131	96.1	32.4	M24	Φ88.900	24.7	12.7	10.3	209.55	107.9	103.9	213.6	41.9
PBL-21	533	120.7	88.90	131	96.1	32.4	M24	Φ88.900	24.7	12.7	10.3	247.65	146.0	142	252	41.9

Specifications

	Clamping Force (kgf)	Max. Drawbar Pull (kgf)	Jaw Stroke mm(dia)	Plunger Stroke (mm)	Chucking Diameter (mm)		Max. Speed (r.m.p)	Weight (kg)	GD ² (kgf·m ²)
					Outside Dia (mm)	Inside Dia (mm)			
PBL-06	6600	2200	7.9	11.3	12.7~120	70~152	4000	18	0.15
PBL-08	8700	2900	9.5	14.3	16~152	76~203	3500	27	0.48
PBL-10	10800	3600	12.7	17.5	50~203	85~235	2500	45	1.23
PBL-12	10800	3600	12.7	17.5	63~241	127~305	2000	67.5	2.42
PBL-15	16500	5500	15.8	22.3	76~317	165~381	1800	84.5	8.49
PBL-18	16500	5500	15.8	22.3	89~394	241~457	1500	120	15.17
PBL-21	16500	5500	15.8	22.3	162~470	317~533	1000	180	25.00

Centralizing

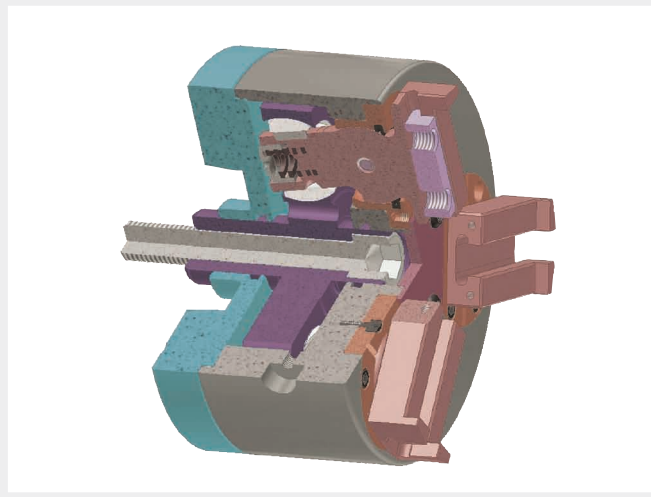

Compensating

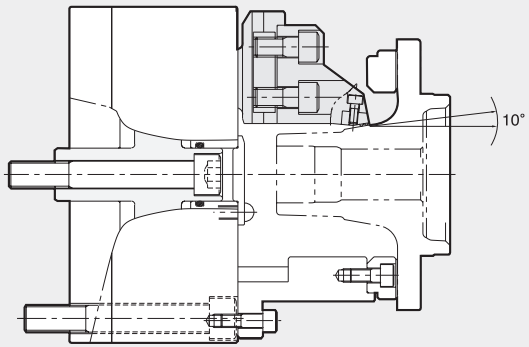
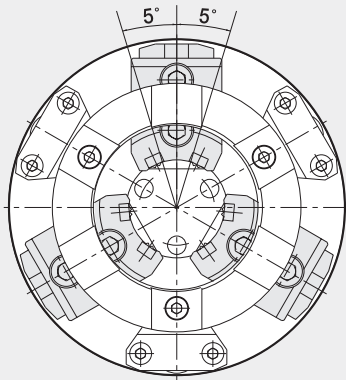
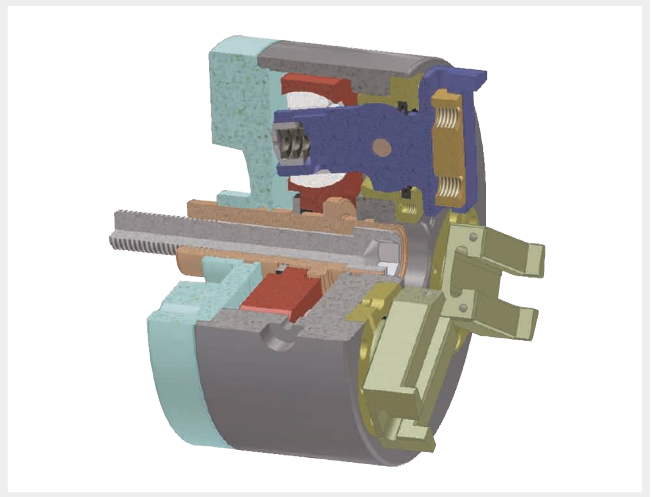

PBL Components

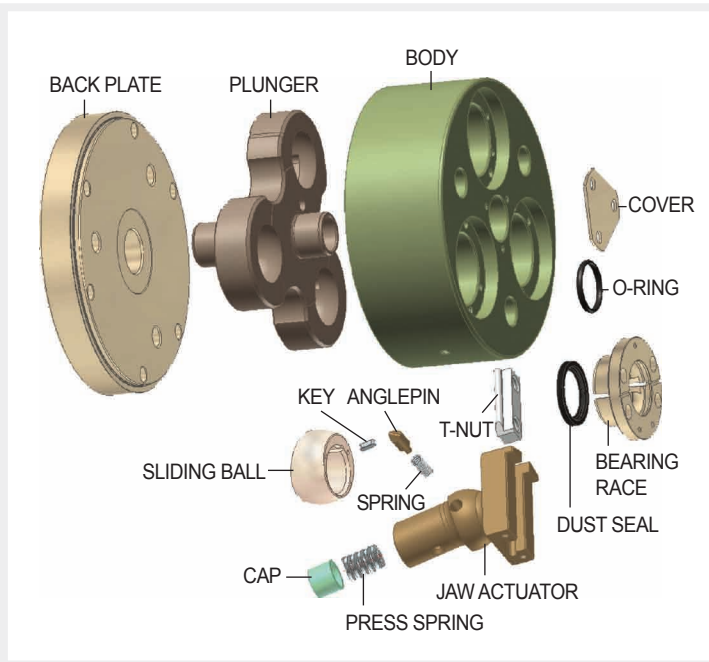

Inserts

Angle Lot Style

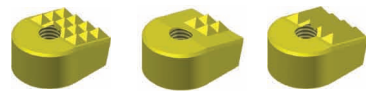

PC127-10SC PC127-4SC PC130-4SC



PC132-4SC PC145-5SC

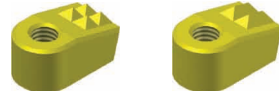

PC127-4SC-S PC130-2SC-S

Round Style



PC070-12SC PC070-4SC

