

ST

STANDARD SCROLL CHUCK (2-PIECE JAW)

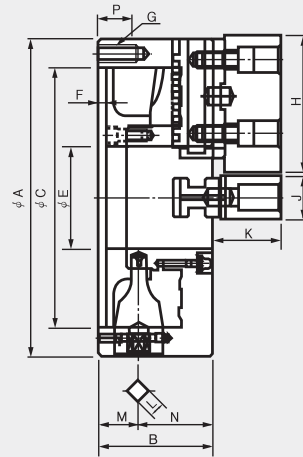

Two-jaw scroll chuck with 2-piece jaw
(incl. soft and hard top jaws)

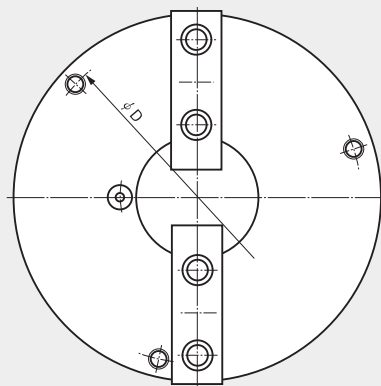

Dimensions

	A	B	C(H6)	D	E	F	G	H	J	K	L	M	N	P
ST-190(7")	192	78.7	155	172	57	5	3-M10	88	32	44.8	11	27.5	51.2	20
ST-230(9")	232	83.7	190	210	75	6	3-M12	100	32	49.8	12	29.5	54.2	25
ST-273(10")	273	88	230	250	89	6	3-M12	110	35	54.32	12	31.5	56.5	25
ST-310(12")	310	96	260	285	100	7	3-M12	125	40	50.58	14	31.5	64.5	25

Specifications

	Max. Static Gripping dia. KN(kgf)	Max. r.p.m min ⁻¹ (r.p.m)	weight kgf	GD ² N·m ² (kgf·m ²)	(Gripping diameter)		Handle Torque N·m(kgf·m)
					(External) φmm	(Internal) φmm	
ST-190(7")	20.7 (2110)	3500	12.6	2.55 (0.26)	4~180	62~170	73.5 (7.5)
ST-230(9")	24.7 (2518)	2900	21.4	6.27 (0.64)	5~220	70~210	98 (10.0)
ST-273(10")	46 (4691)	2500	28	9.90 (1.01)	5~260	70~250	176.5 (18.0)
ST-310(12")	55 (5608)	2200	41	23.0 (2.35)	10~300	86~290	206 (21.0)

※ Specifications are subject to change without notice.